

RoHS

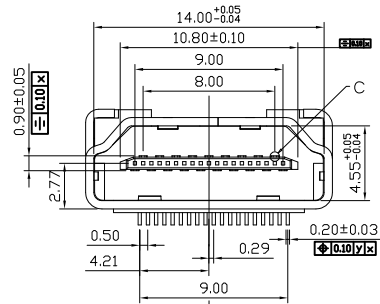

SECTION C
5:1

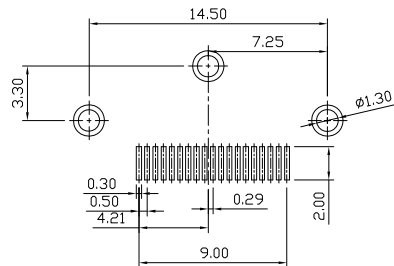
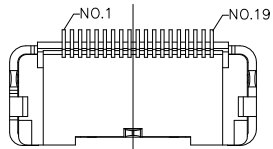
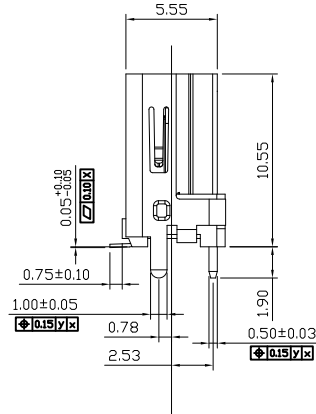
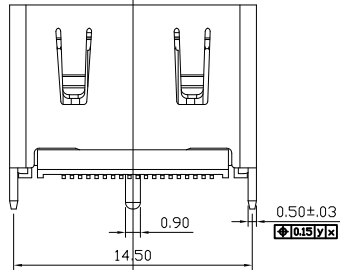
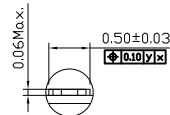

RECOMMENED P.C.B LAYOUT(t=1.6mm)
TOLERANCES UNLESS OTHERWISE SPEC.±0.05

NOTES:

- 1.ELECTRONIC:
CONTACT RESISTANCE: 30 mohm MAX.
INSULATION RESISTANCE: 100Mohm MIN.
WITHSTAND VOVTANGE: AC 500V,1 min.
- 2.MECHANICAL:
DURABILITY: 10000 CYCLE.
3. ENVIRONMENT CHARACTERISTICS:
OPERTING TEMPERATURE -20°C TO +85°C
4. RECOMMANDER PCB THICKNESS 1.60MM

MATERIALS:

Shell: BRASS or Steel
Shell plating: **Nickel**
Insulator:LCP, UL94V-0
Contacts: Brass
Contact plating: See table 1

PART NO: HMA19xxx S01x30
 1 2 3 4 5 6 7 8 9 10

- 1, HDMI A type straight 10.5mm SMT
- 2, Sort: A: A type C: C type D: D type
- 3, Contact No. :
19=19PIN
- 4, Contact Type:
F=Female type,Brass
S=Female type,
- 5, Contact plating :
See table 1
- 6, Specification : B:sloder type P: DIP type
S: SMT type

- 7 , series numder :
01
- 8 , Shell material and Plating:
N=SPCC,Plating nickel
E=Brass,Plating nickel
- 9 , Color :
3=Black
- 10 , Remark:

Gold Plated			Selective Gold Type		
CODE	Contact Area	Other Area	CODE	Contact Area	Other Area
C1	Gold Flash	Gold Flash	E1	Gold Flash	Tin plated
C2	Gold 3u"	Gold Flash	E2	Gold 3u"	Tin plated
C3	Gold 10u"	Gold Flash	E3	Gold 10u"	Tin plated
C4	Gold 15u"	Gold Flash	E4	Gold 15u"	Tin plated
C5	Gold 30u"	Gold Flash	E5	Gold 30u"	Tin plated

DSND	HUANG.J.M	DATE	2011-12-01	SCALE:		NAME:	HDMI A type 19P/Female straight 10.5mm SMT-01
CHKD				VIEW:		Part No:	HMA19 x xxS01 x 3 0
APVD				UNIT:	mm	Customer Part NO:(DWG NO.)	



Dongguan Fushu Electronic Technology Co.,Ltd
Tel:0755-81765247/41 Fax:0769-81765203

unless otherwise specified tolerance:
. X±. 38,
. XX±. 25,
. XXX±. 15,
ANG±2°

MARK	DESCRIPTION	DATE	REVISED	APPROVED
REVISIONS				