

RoHS

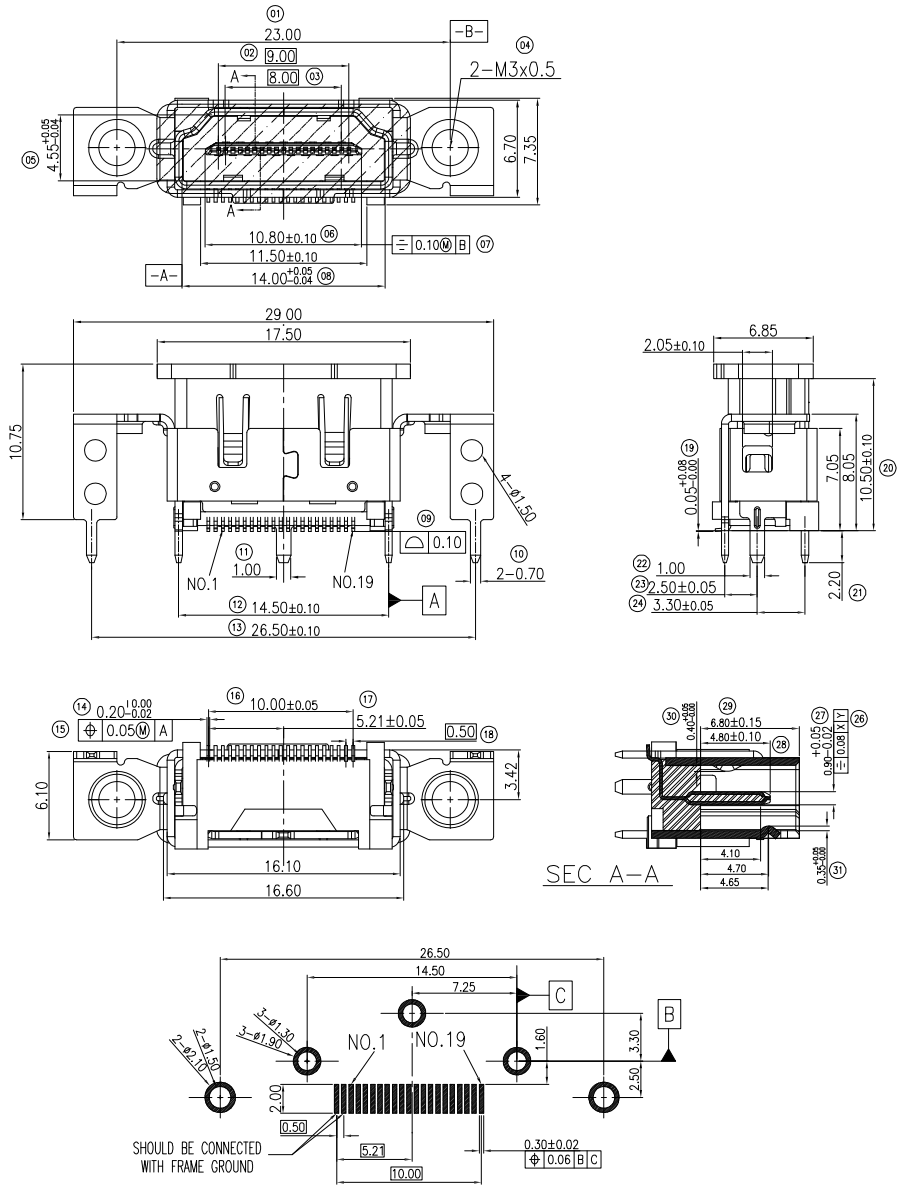

NOTES:

- 1.ELECTRONIC:
CONTACT RESISTANCE: 30 mohm MAX.
INSULATION RESISTANCE: 100Mohm MIN.
WITHSTAND VOLTAGE: AC 500V,1 min.
- 2.MECHANICAL:
DURABILITY: 10000 CYCLE.
3. ENVIRONMENT CHARACTERISTICS:
OPERING TEMPERATURE -20°C TO +85°C
4. RECOMMANDER PCB THICKNESS 1.60MM

MATERIALS:

Shell: BRASS or Steel
Shell plating: Nickel
Insulator:LCP, UL94V-0
Contacts: Brass
Contact plating: See table 1

PART NO: HMA19x xx S 0 3 x 3 0
1 2 3 4 5 6 7 8 9 10

- | | |
|---|---|
| 1, HDMI A type straight 10.5mm SMT | 7, series number :
03 |
| 2, Sort: A: A type C: C type D: D type | 8, Shell material and Plating:
N=SPCC,Plating nickel
E=Brass,Plating nickel |
| 3, Contact No. :
19=19PIN | 9, Color :
1=White
2=Blue
3=Black |
| 4, Contact Type:
F=Female type,Brass
S=Female type, | 10, Remark: |
| 5, Contact plating :
See table 1 | |
| 6, Specification : B:sloder type P: DIP type
S: SMT type | |

Gold Plated		Selective Gold Type			
CODE	Contact Area	Other Area	CODE	Contact Area	Other Area
C1	Gold Flash	Gold Flash	E1	Gold Flash	Tin plated
C2	Gold 3u"	Gold Flash	E2	Gold 3u"	Tin plated
C3	Gold 10u"	Gold Flash	E3	Gold 10u"	Tin plated
C4	Gold 15u"	Gold Flash	E4	Gold 15u"	Tin plated
C5	Gold 30u"	Gold Flash	E5	Gold 30u"	Tin plated

RECOMMEN P.C.B. LAYOUT(T=1.6mm)
TOLERANCES UNLESS OTHERWISE SPEC. ±0.05

unless otherwise specified tolerance:

- . X ± .38,
- . XX ± .25,
- . XXX ± .15,

ANG ± 2°

DSND	HUANG.J.M	DATE	2011-12-01	SCALE:	
CHKD				VIEW:	
APVD				UNIT:	mm

Dongguan Fushu Electronic Technology Co.,Ltd
Tel:0755-81765247/41 Fax:0769-81765203

NAME:
HDMI A type 19P/Female straight 10.5mm SMT-03

Part No:
HMA19 x xxS03 x 3 0

Customer Part NO:(DWG NO.)

MARK	DESCRIPTION	DATE	REVISED	APPROVED

REVISIONS