

RoHS

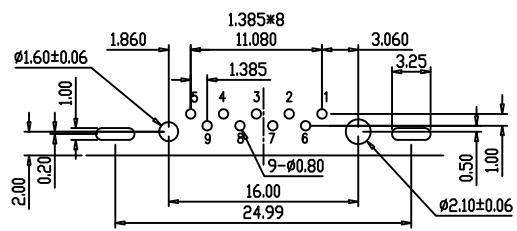
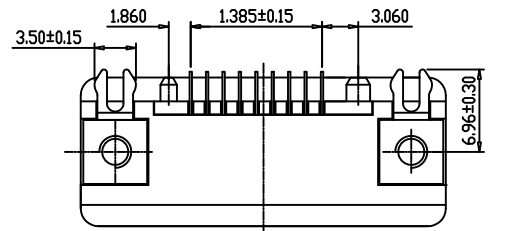
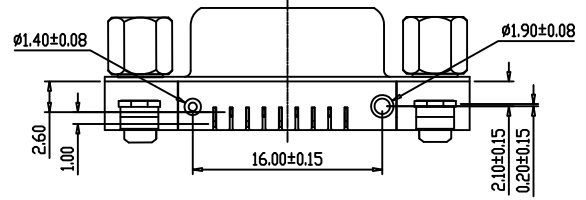
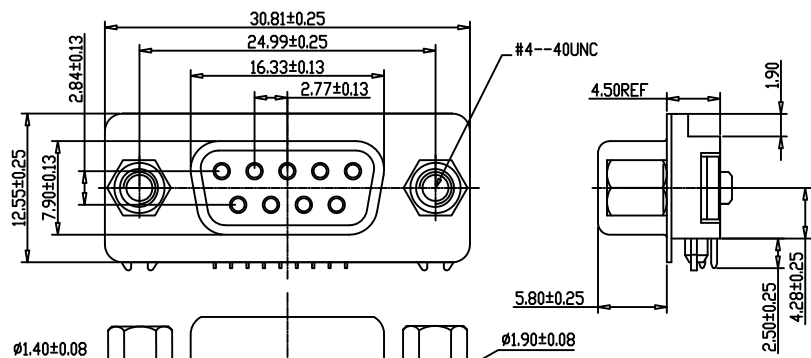
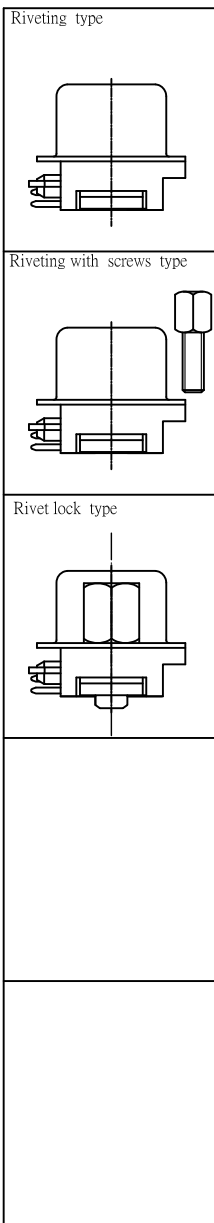

RECOMMENDED P.C.B. LAYOUT

SPECIFICATIONS:
ELECTRICAL SPECIFICATION

Contact Current Rating: 5 Amperes
Dielectric Withstanding Voltage: AC 1000/60ses.r.m.s.
Insulation Resistance: 5000 Megohm Min. at DC 500V
Contact Resistance: 25 milliohm Max.
Operating Tempetature: -55°c ~ +105°c

MATERIALS:

Contacts: Brass
Contacts: See number description
Insulator: PBT+G.F UL94V-0
Shell: Steel

PART NO:

ZDS H09F E 1 BGN 3 0
1 2 3 4 5 6 7 8 9 10

1, D-SUB P.C.B SLIM 9PIN Male Dual Row Right Angle Type(Stamped PIN)	7, Accessories :
2, board lock material:	0 : No accessories
H: Brass	A: With iron hexagon screw, 4.8*11.8mm
3, Contact No. : 09=09PIN	B: With brass hexagon screw, 4.8*11.8mm
4, Contact Type: F=Female type, Brass (stamped PIN)	E : Lock brass hexagon screw, 5.8*12.8mm
5, Contact plating : See table 1	G: Lock iron hexagon screw, 4.8*11.8mm
6, Assembly : B=Riveting type	J : Lock iron hexagon screw, 5.8*12.8mm
	K : Lock brass hexagon screw, 4.8*11.8mm
	8, Shell material and Plating:
	N=SPCC, Plating nickel
	T=SPCC, Plating Tin
	9, Color :
	1=White
	2=Blue
	3=Black
	10, Remark:

Table 1

Gold Plated			Selective Gold Type		
CODE	Contact Area	Other Area	CODE	Contact Area	Other Area
C1	Gold Flash	Gold Flash	E1	Gold Flash	Tin plated
C2	Gold 3u"	Gold Flash	E2	Gold 3u"	Tin plated
C3	Gold 10u"	Gold Flash	E3	Gold 10u"	Tin plated
C4	Gold 15u"	Gold Flash	E4	Gold 15u"	Tin plated
C5	Gold 30u"	Gold Flash	E5	Gold 30u"	Tin plated

DSND	HUANGJM	DATE	2011-12-01	SCALE:	
CHKD				VIEW:	
APVD				UNIT:	mm

Dongguan Fushu Electronic Technology Co., Ltd
Tel: 0755-81765247/41 Fax: 0769-81765203

NAME:
D-SUB P.C.B SLIM 9PIN Female Dual Row Right Angle Type(Stamped PIN)

Part No:
ZDS xxx F x x x x x x x

Customer Part NO:(DWG NO.)

unless otherwise specified tolerance:

. X ± . 38, ANG ± 2°
. XX ± . 25,
. XXX ± . 15,

MARK	DESCRIPTION	DATE	REVISED	APPROVED

REVISIONS