

RoHS

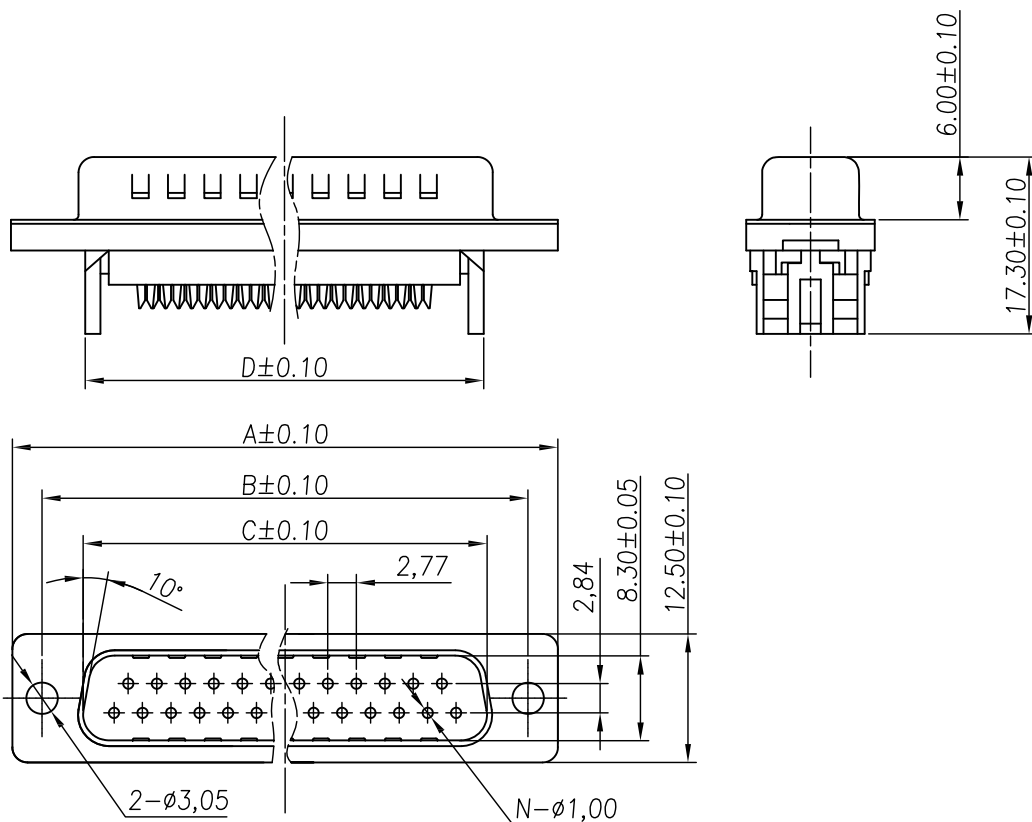

**SPECIFICATIONS:**  
**ELECTRICAL SPECIFICATION**

Contact Current Rating: 3 Amperes  
 Dielectric Withstanding Voltage: AC 1000/60ses.r.m.s.  
 Insulation Resistance: 5000 Megohm Min. at DC 500V  
 Contact Resistance: 25 milliohm Max.  
 Operating Tempetature: -55°c ~ +105°c

**MATERIALS:**

Contacts: Brass  
 Contacts: See number description  
 Insulator: PBT+G.F UL94V-0  
 Shell: Steel or Stainless steel

PART NO:

Z 1 D F 1 5 F E 1 B G N 3 0

1, D-SUB Female Dual Row IDC Type(Stamped PIN)	7 · Accessories :
2, board lock material: F: Iron N: Brass	O : No accessories A: With iron hexagon screw, 4.8*11.8mm B: With brass hexagon screw, 4.8*11.8mm E : Lock brass hexagon screw, 5.8*12.8mm G: Lock iron hexagon screw, 4.8*11.8mm J : Lock iron hexagon screw, 5.8*12.8mm K : Lock brass hexagon screw, 4.8*11.8mm
3, Contact No. : 15=15PIN      26=26PIN 44=44PIN      62=62PIN	8 · Shell material and Plating: N=SPCC, Plating nickel D= Stainless steel, Passivation C=Stainless steel, Plating nickel T=SPCC, Plating Tin
4, Contact Type: M=Male type (stamped PIN)	9 · Color : 1=White 2=Blue 3=Black
5, Contact plating : See table 2	10 · Remark:
6, Assembly : A=Fork lock type B=Riveting type F=Front hole rivet Round nut type, 6.0mm	

Table 2

Gold Plated			Selective Gold Type		
CODE	Contact Area	Other Area	CODE	Contact Area	Other Area
C1	Gold Flash	Gold Flash	E1	Gold Flash	Tin plated
C2	Gold 3u"	Gold Flash	E2	Gold 3u"	Tin plated
C3	Gold 10u"	Gold Flash	E3	Gold 10u"	Tin plated
C4	Gold 15u"	Gold Flash	E4	Gold 15u"	Tin plated
C5	Gold 30u"	Gold Flash	E5	Gold 30u"	Tin plated

Table 1

NUMBER OF CONTACTS	A ±0.25	B ±0.25	C ±0.38	D ±0.08
15	16.92	24.99	30.85	2.29
26	25.25	33.32	39.14	2.29
44	38.96	47.04	53.04	2.29
62	55.42	63.50	69.32	2.41

unless otherwise specified tolerance:

. X ± .38,  
 . XX ± .25,  
 . XXX ± .15,

ANG ± 2°

DSND	HUANGJM	DATE	2011-12-01	SCALE:		NAME:	D-SUB Male Dual Row IDC Type(Stamped PIN)
CHKD				VIEW:			
APVD				UNIT:	mm		Part No: Z1DXXXXXXX
Dongguan Fushu Electronic Technology Co., Ltd Tel: 0755-81765247/41 Fax: 0769-81765203				Customer Part NO: (DWG NO.)			

MARK	DESCRIPTION	DATE	REVISED	APPROVED
REVISIONS				

1  
2  
3  
4  
5  
6  
7  
8  
9  
10  
11  
12  
13  
14  
15

ROHS

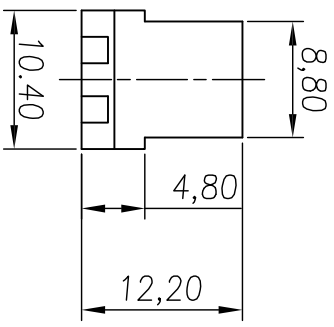
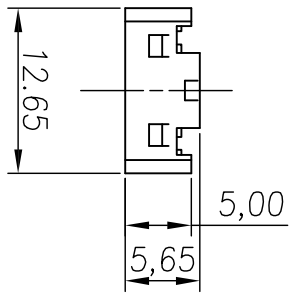
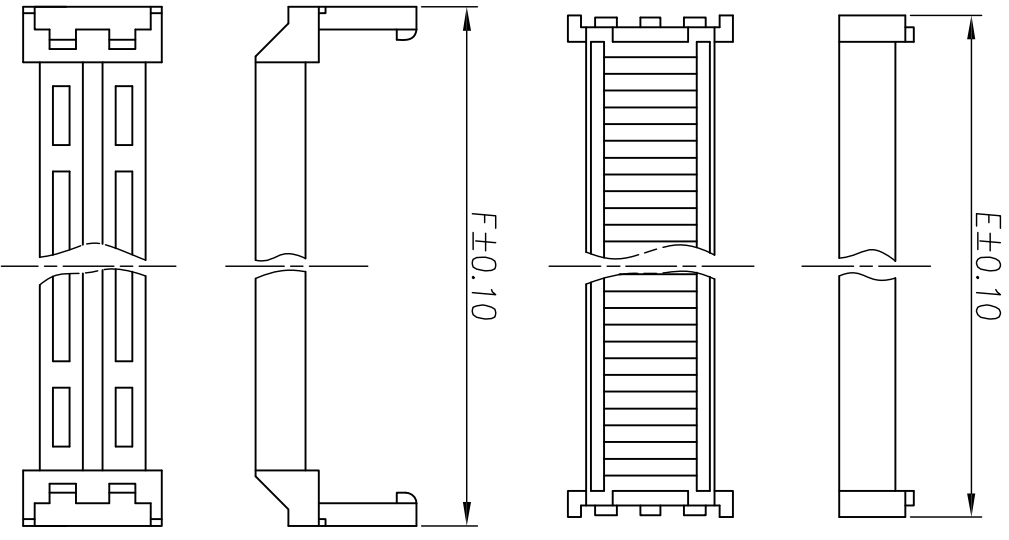

Pin	DB9Pin	DB15Pin	DB25Pin	DB37Pin
E	15.05	23.65	37.05	53.70
F	18.80	26.90	40.50	56.65

MARK	DESCRIPTION	REVISIONS	DATE	REVISED	APPROVED

unless otherwise specified tolerance:  
 .X±.38,  
 .XX±.25,  
 .XXX±.15,  
 ANG±2°

DSND	HUANGJM	DATE	2011-12-01	SCALE:		NAME:	ZDD 0xx FS) x x x x x x x x
CHKD		VIEW:		UNIT:	mm		
APPD							

Dongguan Fishu Electronic Technology Co., Ltd  
 Tel:0755-81765247/41 Fax:0769-81765203  
 Part No: ZDD 0xx FS) x x x x x x x x  
 Customer Part No.(DWG NO.)