

RoHS

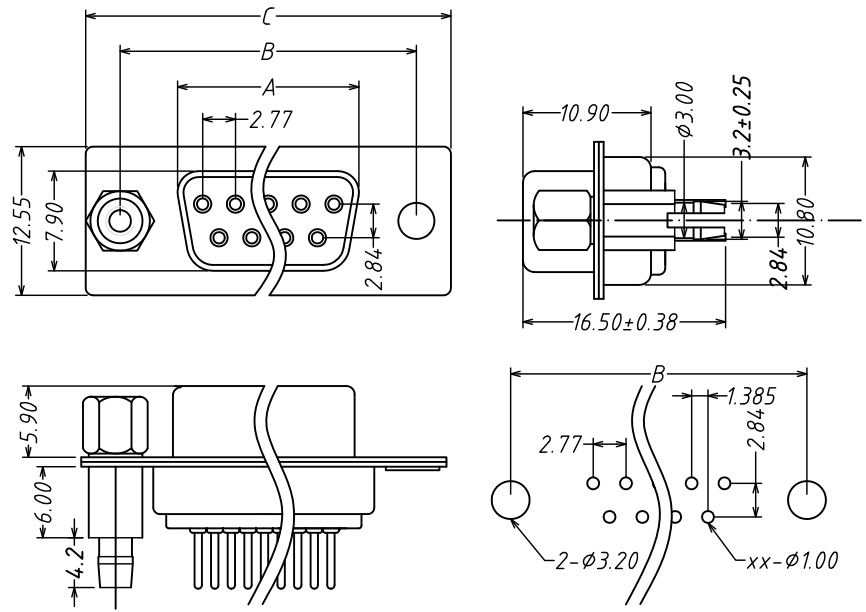
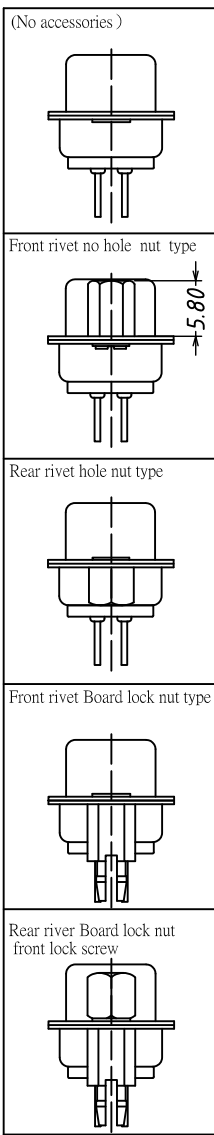

RECOMMENDED PCB LAYOUT

Table 1

CODE	H
D	3.00
K	4.00
N	6.30
A	5.80

Table 2

NUMBER OF CONTACTS	A	B	C
	±0.25	±0.13	±0.38
9	16.30	24.99	30.85
15	25.25	33.32	39.14
25	38.96	47.04	53.04
37	55.42	63.50	69.32

Table 3

Gold Plated			Selective Gold Type		
CODE	Contact Area	Other Area	CODE	Contact Area	Other Area
C1	Gold Flash	Gold Flash	E1	Gold Flash	Tin plated
C2	Gold 3u"	Gold Flash	E2	Gold 3u"	Tin plated
C3	Gold 10u"	Gold Flash	E3	Gold 10u"	Tin plated
C4	Gold 15u"	Gold Flash	E4	Gold 15u"	Tin plated
C5	Gold 30u"	Gold Flash	E5	Gold 30u"	Tin plated

SPECIFICATIONS:
ELECTRICAL SPECIFICATION

Contact Current Rating: 5 Amperes
 Dielectric Withstanding Voltage: AC 1000/60ses.r.m.s.
 Insulation Resistance: 5000 Megohm Min. at DC 500V
 Contact Resistance: 25 milliohm Max.
 Operating Tempetature: -55°c__+105°c

MATERIALS:

Contacts: Brass
 Contacts: See number description
 Insulator: PBT+G.F UL94V-0
 Shell: Steel or Stainless steel

PART NO: ZDP 0xx 1 xx x x x x x

- D-SUB P.C.B Female Dual Row Straight Type(Machined PIN)
- Board lock material: N/A
- Contact No.: 09=9PIN 15=15PIN 25=25PIN 37=37PIN
- Contact Type: F=Female type (Machined PIN)
- Contact plating: See table 3
- Assembly: A=Rear rivet hole hexagon nut,5.8mm B=No accessories C=Front rivet no hole hexagon nut,5.8mm D=Rear rivet hole hexagon nut,3.0mm K=Rear rivet hole hexagon nut,4.0mm L=Rear rivet hole hexagon nut,6.5mm N=Rear rivet hole hexagon nut,6.3mm G=Front rivet Board lock nut type
- Accessories: O: No accessories E: Lock brass hexagon screw,5.8*12.8mm G: Lock iron hexagon screw · 4.8*12.8 H: Lock iron hexagon screw · 4.8*9.6mm J: Lock iron hexagon screw · 5.8*12.8mm K: Lock brass hexagon screw,4.8*11.8mm
- Shell material and Plating: N=SPCC,Plating nickel A=SPCC,Front shell plating nickel and rear shell tin D= Stainless steel,Passivation C=Stainless steel, Plating nickel T=SPCC,Plating Tin
- Color: 1=White 2=Blue 3=Black
- Remark:

MARK	DESCRIPTION	DATE	REVISED	APPROVED
REVISIONS				

unless otherwise specified tolerance:
 . X ± . 38,
 . XX ± . 25,
 . XXX ± . 15,
 ANG ± 2°

DSND	HUANGJM	DATE	2011-12-01	SCALE:	
CHKD				VIEW:	
APVD				UNIT:	mm

Dongguan Fushu Electronic Technology Co.,Ltd
 Tel:0755-81765247/41 Fax:0769-81765203

NAME: D-SUB P.C.B Female Dual Row Straight Type(Machined PIN)
 Part No: ZDP 0xx F xx x x x x x
 Customer Part NO:(DWG NO.)