

RoHS Compliant

NOTES:

MATERIAL:

- 1. HOUSING MATERIAL :PBT,PA66,PA46(UL 94V-0)
- 2. CONTACT MATERIAL :ROUND PINS-0.46mm DIAMETER PHOSPHOR BRONZE;
GOLD PLATING OVER NICKEL

ELECTRICAL/PHYSICAL:

- 1. VOLTAGE RATING :125 VAC RMS
- 2. CURRENT RATING :1.5 AMP
- 3. CONTACT RESISTANCE :30 MILLIOHMS MAX2
- 4. INSULATION RESISTANCE :500 MEGOHMS MIN @500V DC
- 5. DIELECTRIC WITHSTANDING RISTANCE :1000V AC RMS 60Hz. 1MIN
- 6. DURABILITY :750 CYCLES MIN
- 7. TEMPERATURE :-40 °C/+85°C

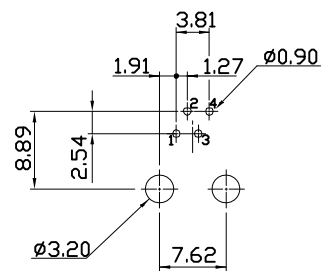
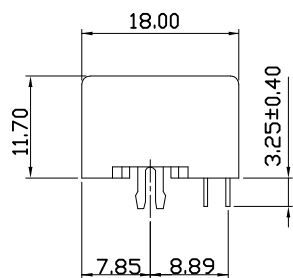
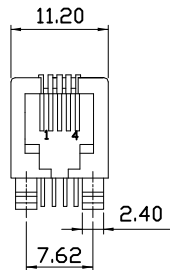

PCBLAYOUT
(TOPView)

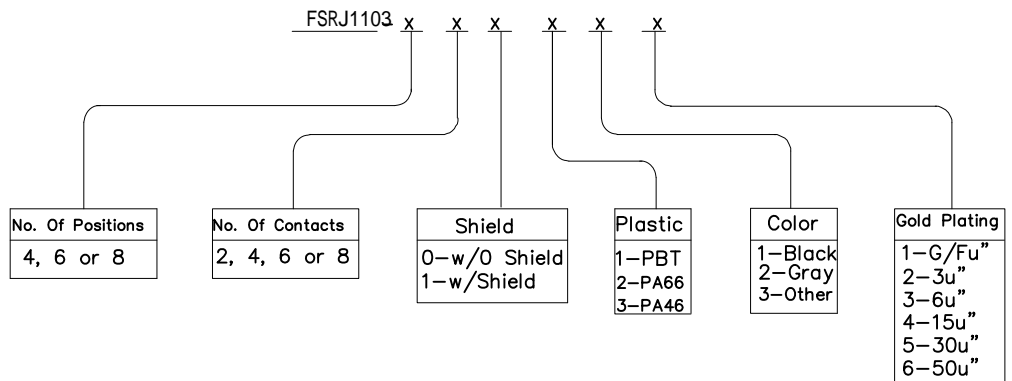
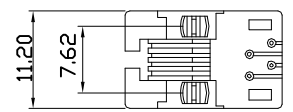

MARK	DESCRIPTION	DATE	REVISED	APPROVED
REVISIONS				

unless otherwise specified tolerance:
MM
 .00±0.25
 .000±0.13
 .0000±0.05

DSND	HUANG.J.M	DATE	2018-1-18	SCALE:	
CHKD				VIEW:	
APVD				UNIT:	mm

Dongguan Fushu Electronic Technology Co.,Ltd
 Tel:0755-81765247/41 Fax:0769-81765203

NAME: **SIDE ENTRY PCB JACK**

Part No: **FSRJ1103-XXXXXX**

Customer Part NO:(DWG NO.)