

RoHS Compliant

NOTES:

MATERIAL:

- 1. HOUSING MATERIAL : PBT,PA66,PA46(UL 94V-0)
- 2. CONTACT MATERIAL : FLAT PINS-0.35mm THICKNESS PHOSPHOR BRONZE.;
GOLD PLATING OVER NICKEL IN CONTACT AREA;
TIN PLATING OVER NICKEL IN SOLDER AREA

ELECTRICAL/PHYSICAL:

- 1. VOLTAGE RATING : 125 VAC RMS
- 2. CURRENT RATING : 1.5 AMP
- 3. CONTACT RESISTANCE : 30 MILLIOHMS MAX2
- 4. INSULATION RESISTANCE : 500 MEGOHMS MIN @500V DC
- 5. DIELECTRIC WITHSTANDING RESISTANCE : 1000V AC RMS 60Hz. 1MIN
- 6. DURABILITY : 750 CYCLES MIN
- 7. TEMPERATURE : -40 °C/+85°C

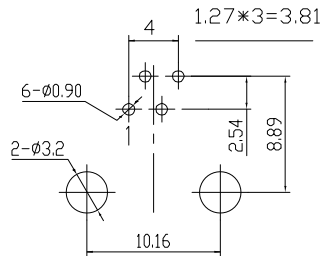
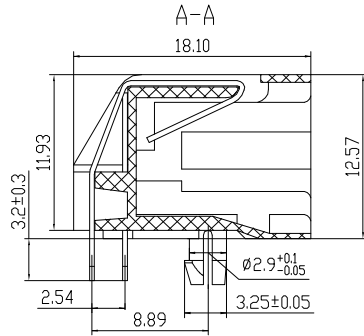
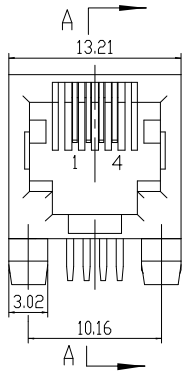

PC BOARD LAYOUT
THICKNESS=1.6MM

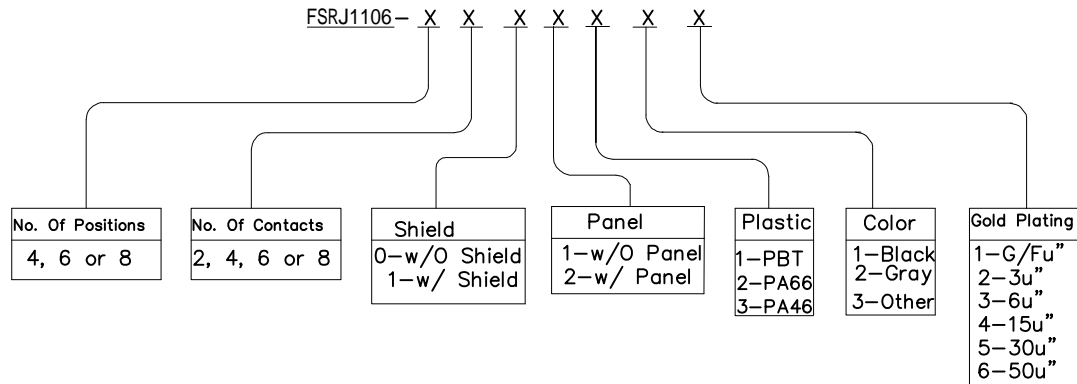

MARK	DESCRIPTION	DATE	REVISED	APPROVED
REVISIONS				

unless otherwise specified tolerance:
MM
.00±0.25
.000±0.13
.0000±0.05

DSND	HUANGJM	DATE	2018-1-18	SCALE:	NAME:
CHKD				VIEW:	SIDE ENTRY PCB JACK
APVD				UNIT: mm	Part No: FSRJ1106-XXXXXX
Dongguan Fushu Electronic Technology Co.,Ltd Tel:0755-81765247/41 Fax:0769-81765203				Customer Part NO:(DWG NO.)	