

RoHS Compliant

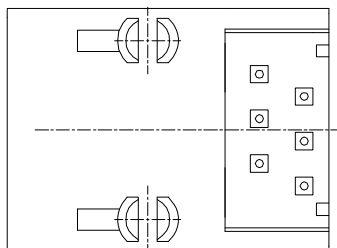
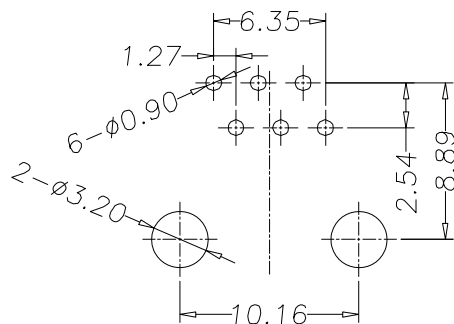
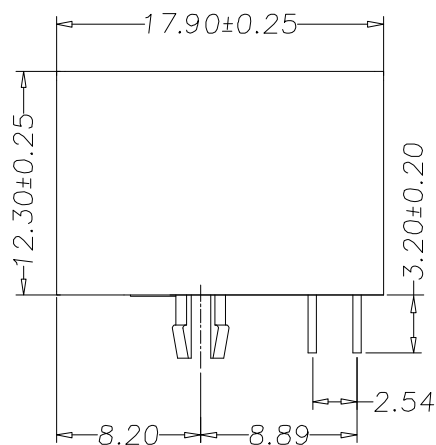
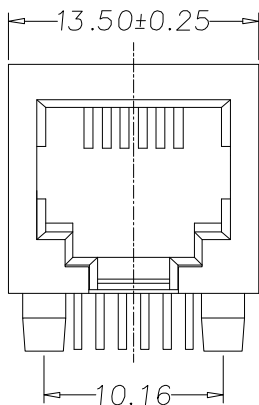

NOTES:

MATERIAL:

- 1.HOUSING
- 2.CONTACT
- FLAT PIN
- 3.SHIELD

:GLASS FILLED POLYESTER UL94V-0

:PHOSPHOR BRONZE $\phi=0.46\text{mm}$ GOLD PLATING OVER NICKEL.
:0.20mm THICKNESS COPPER ALLOY WITH NICKEL PLATED.

ELECTRICAL:

- 1.VOLTAGE RATING :125V AC.
- 2.CURRENT RATING :1.5AMP.
- 3.CONTACT RESISTANCE :30 MILLIOHMS MAX.
- 4.INSULATION RESISTANCE :500 MEGOHMS MIN @ 500V DC.
- 5.DIELECTRIC WITHSTANDING VOLTAGE :1000V AC RMS 50Hz OR 60Hz. 1MIN.

MECHANICAL:

- 1.INSETION FORCE :2.2Kg MAX.
- 2.RETENTION STRENGTH :7.7Kg BETWEEN JACK AND PLUG
- 3.DURRABILITY :750 CYCLES MIN.

ENVIRONMENTAL:

- 1.STORAGE :-40°C~+85°C
- 2.OPERATION :-40°C TO 70°C

PART NUMBER:

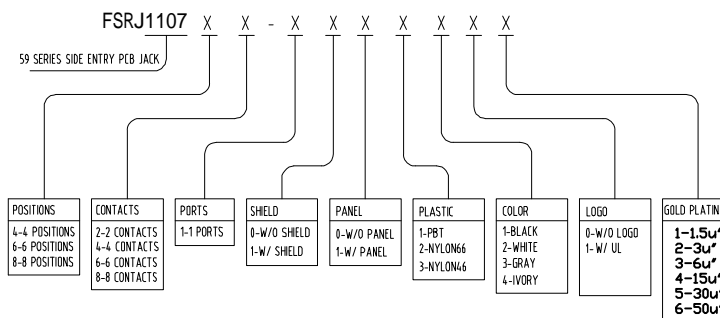

PC Board Layout

DSND	HUANGJM	DATE	2018-1-18	SCALE:		NAME:	
CHKD				VIEW:			
APVD				UNIT:	mm		
Dongguan Fushu Electronic Technology Co.,Ltd Tel:0755-81765247/41 Fax:0769-81765203						Part No: FSRJ1107-XXXXXXXX	
						Customer Part NO:(DWG NO.)	

					unless otherwise specified tolerance:
					MM
					.00±0.25
					.000±0.13
					.0000±0.05
MARK	DESCRIPTION	DATE	REVISED	APPROVED	REVISIONS