

RoHS Compliant

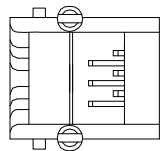
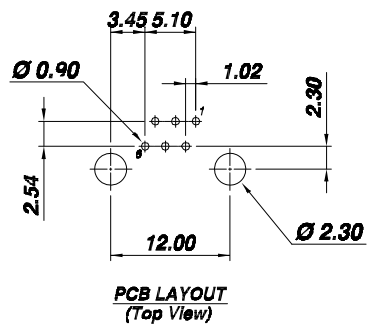
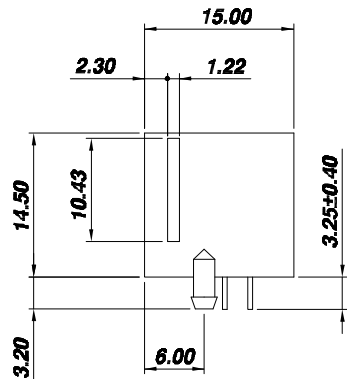
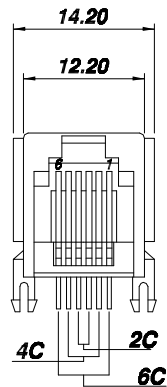

NOTES:

MATERIAL:

- 1. HOUSING MATERIAL :PBT,PA66,PA46(UL 94V-0)
- 2. CONTACT MATERIAL :ROUND PINS-0.46mm DIAMETER PHOSPHOR BRONZE; GOLD PLATING OVER NICKEL

ELECTRICAL/PHYSICAL:

- 1. VOLTAGE RATING :125 VAC RMS
- 2. CURRENT RATING :1.5 AMP
- 3. CONTACT RESISTANCE :30 MILLIOHMS MAX2
- 4. INSULATION RESISTANCE :500 MEGOHMS MIN @500V DC
- 5. DIELECTRIC WITHSTANDING RISTANCE :1000V AC RMS 60Hz. 1MIN
- 6. DURABILITY :750 CYCLES MIN
- 7. TEMPERATURE :-40 °C/+85°C

FSRJ1108 - X X - X X X X X X X X

No. Of Positions 4, 6 or 8	No. Of Contacts 2, 4, 6 or 8	Shield 0-w/0 Shield 1-w/ Shield	High 1-H=13 2-H=15	Panel 0-w/0 Panel 1-w/ Panel	Gap 0-w/0 Gap 1-w/ Gap	Plastic 1-PBT 2-PA66 3-PA46	Color 1-Black 2-Gray 3-Other	Gold Plating 1-G/Fu" 2-3u" 3-6u" 4-15u" 5-30u" 6-50u"
-------------------------------	---------------------------------	---------------------------------------	--------------------------	------------------------------------	------------------------------	--------------------------------------	---------------------------------------	---

DSND	HUANGJM	DATE	2018-1-18	SCALE:		NAME:	SIDE ENTRY PCB JACK
CHKD				VIEW:			
APVD				UNIT:		mm	Part No: FSRJ1108-XXXXXXXX
Dongguan Fushu Electronic Technology Co.,Ltd Tel:0755-81765247/41 Fax:0769-81765203						Customer Part NO:(DWG NO.)	

REVISIONS					unless otherwise specified tolerance: MM .00±0.25 .000±0.13 .0000±0.05
MARK	DESCRIPTION	DATE	REVISED	APPROVED	