

RoHS Compliant

NOTES:

MATERIAL:

- 1. HOUSING MATERIAL : PBT,PA66,PA46(UL 94V-0)
- 2. CONTACT MATERIAL : ROUND PINS-0.46mm DIAMETER PHOSPHOR BRONZE; GOLD PLATING OVER NICKEL
- 3. SHIELD : 0.20mm THICKNESS COPPER ALLOY WITH NICKEL PLATED

ELECTRICAL/PHYSICAL:

- 1. VOLTAGE RATING : 125 VAC RMS
- 2. CURRENT RATING : 1.5 AMP
- 3. CONTACT RESISTANCE : 30 MILLIOHMS MAX2
- 4. INSULATION RESISTANCE : 500 MEGOHMS MIN @500V DC
- 5. DIELECTRIC WITHSTANDING RESISTANCE : 1000V AC RMS 60Hz. 1MIN
- 6. DURABILITY : 750 CYCLES MIN
- 7. TEMPERATURE : -40 °C/+85°C

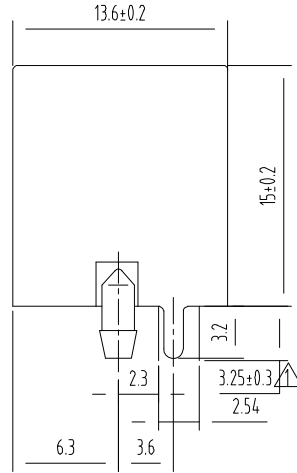
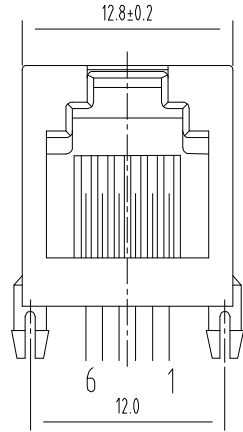

PCB LAYOUT

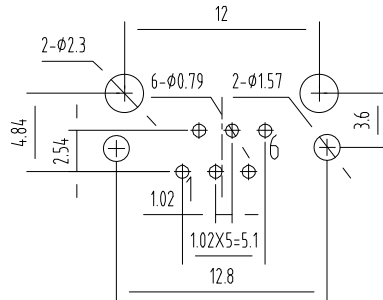

PC Board Layout
Component Side Shown

FSRJ1109 - X X -X X X X X X X

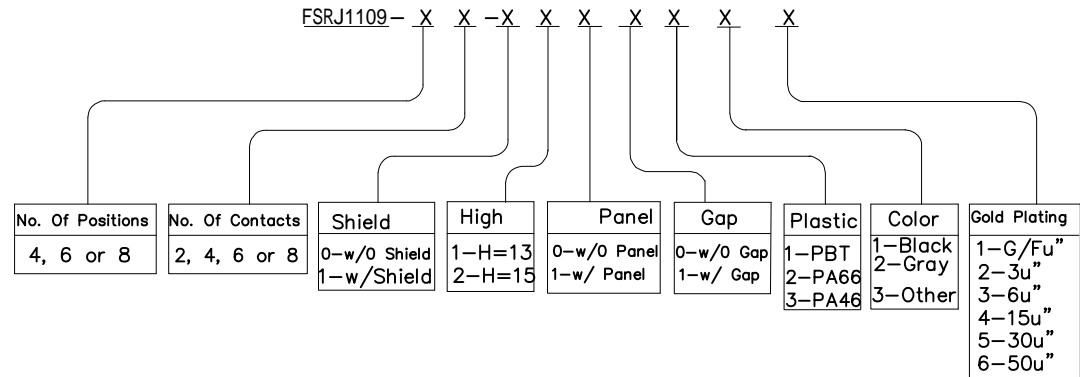

DSND	HUANGJM	DATE	2018-1-18	SCALE:	NAME:
CHKD				VIEW:	SIDE ENTRY PCB JACK
APVD				UNIT: mm	Part No: FSRJ1109-XXXXXXXX
unless otherwise specified tolerance: MM .00±0.25 .000±0.13 .0000±0.05				Customer Part NO:(DWG NO.)	
				Dongguan Fushu Electronic Technology Co.,Ltd Tel:0755-81765247/41 Fax:0769-81765203	

MARK	DESCRIPTION	DATE	REVISED	APPROVED
REVISIONS				