

RoHS Compliant

NOTES:

MATERIAL:

- 1. HOUSING MATERIAL : PBT,PA66,PA46(UL 94V-0)
- 2. CONTACT MATERIAL : ROUND PINS-0.46mm DIAMETER PHOSPHOR BRONZE; GOLD PLATING OVER NICKEL

ELECTRICAL/PHYSICAL:

- 1. VOLTAGE RATING : 125 VAC RMS
- 2. CURRENT RATING : 1.5 AMP
- 3. CONTACT RESISTANCE : 30 MILLIOHMS MAX2
- 4. INSULATION RESISTANCE : 500 MEGOHMS MIN @500V DC
- 5. DIELECTRIC WITHSTANDING RISTANCE : 1000V AC RMS 60Hz. 1MIN
- 6. DURABILITY : 750 CYCLES MIN
- 7. TEMPERATURE : -40 °C/+85°C

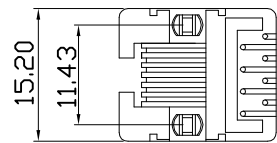
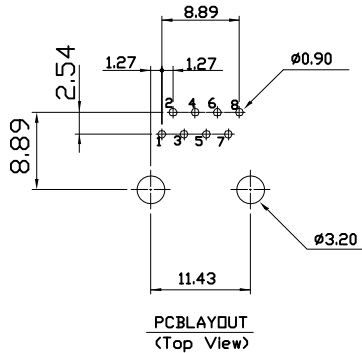
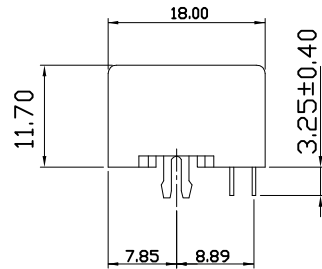
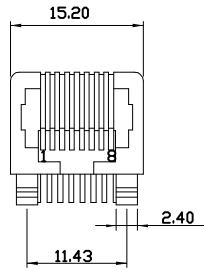

FSRJ4509 - X X X X X X

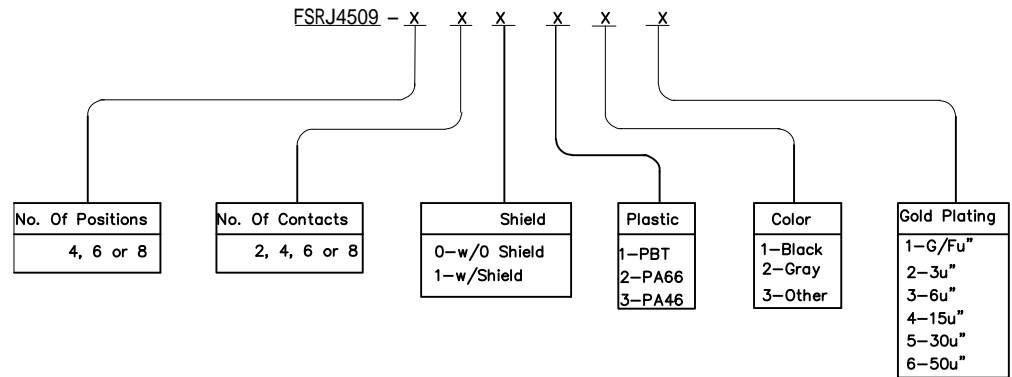

MARK	DESCRIPTION	DATE	REVISED	APPROVED
REVISIONS				

unless otherwise specified tolerance:
MM
 .00±0.25
 .000±0.13
 .0000±0.05

DSND	HUANGJM	DATE	2018-1-18	SCALE:	NAME:
CHKD				VIEW:	SIDE ENTRY PCB JACK
APVD				UNIT:	mm
Dongguan Fushu Electronic Technology Co.,Ltd Tel:0755-81765247/41 Fax:0769-81765203					Part No: FSRJ4509-XXXXXX
					Customer Part NO:(DWG NO.)